

Ford

Accessories

Ranger | Everest





Ford Ranger Accessories

For the adventurer, the family of travellers or the hard working tradie - whoever you may be, ARB will be there every step of your journey, offering you the highest calibre 4x4 accessories on the market.



With an unrelenting commitment to innovation and engineering excellence, an extensive network of retail outlets and workshops around the country and exceptional aftersales support, you can be assured you're getting quality products, reliable service and sound advice.

Protection Equipment

OUR PROTECTION
GEAR HAS BEEN
DESIGNED FOR
MAXIMUM STRENGTH,
STYLE AND
PRACTICALITY.

Vehicle protection is one of the main priorities for owners of four wheel drives and commercial vehicles. Bull bars, rear bars and side rails and steps will help prevent expensive panel damage, especially when heading off road, as well as providing a solid base on which to mount a range of accessories like winches, driving lights and antennas. Like all of our products, our protection gear has been designed for maximum strength, style and practicality.







Summit Bull Bar

Built on ARB's tradition of pioneering innovation and bringing a fresh, contemporary design for modern day vehicles, the ARB Summit bull bar uses press forming technology and incorporates a larger tube diameter to deliver the ultimate in strength and aesthetics. Compatible with the latest vehicle safety systems and encompassing a range of practical features including provision for driving lights, communication antennas and electric winches, as well as protection against corrosion, the ARB Summit bull bar represents the pinnacle in frontal protection.

The Summit bull bar comes standard in a hardwearing black powder coat finish, with the option to colour code.

→ Available for Ranger, Everest



Summit Sahara Bar

Featuring many of the protection and design elements of the Summit bull bar, the Summit Sahara bar offers modern vehicle owners the choice of optioning a polished or painted aluminium centre tube for a uniquely different look to the more traditional bull bar, while maintaining a high level of impact protection.

The Summit Sahara bar comes standard in a hardwearing black powder coat finish, with the option to colour code.

→ Available for Ranger, Everest

8







Alloy Bull Bar

The ARB Alloy bull bar offers yet another choice for frontal protection. With styling elements designed to complement modern four wheel drive vehicles, the bar is manufactured from lightweight and corrosion resistant alloys, with a steel substructure and mounting system for maximum strength.

Like all other ARB bars, the Alloy bull bar utilises renowned manufacturing processes throughout, ensuring strength and durability, and includes provisions for driving lights, communication antennas and electric winches.

→ Available for Ranger, Everest



Commercial Bull Bar

Favoured by government and fleet operators, the Commercial bull bar uses a simplified manufacturing process to achieve cost-effective vehicle protection without some of the more aesthetic features. Incorporating a range of practical features, the Commercial bull bar provides a solid platform on which to add a range of accessories including electric winches, auxiliary driving lights, communication antennas and safety flags.

→ Available for Ranger



SmartBar

Manufactured from polyethylene plastic, the SmartBar is a lighter alternative to steel bars and a popular choice amongst fleet and emergency service operators. Available in a variety of colours, depending on the vehicle, the SmartBar is environmentally friendly and easy to install. The SmartBar range is air bag compatible and has provisions for driving lights and winches.

→ Available for Ranger, Everest





Summit Rear Step Tow Bar

Providing both maximum towing capacity and increased rear end protection on and off road, the Summit rear step tow bar combines class-leading design, proven ARB engineering and a no compromise approach to protection and performance. Built around a tubular steel subframe, the Summit rear step tow bar includes an integrated tow hitch, provisions for an ARB air compressor outlet, trailer camera wiring, 50 amp Anderson plug and trailer plug wiring.

With press forming used throughout for increased strength, the Summit rear step tow bar is ready for the most demanding off road use.

→ Available for Ranger



Summit Side Rails and Steps

ARB offers side rails and steps specifically designed to protect your doors, side sills and front quarter panels from damage off road, as well as aiding access to and from the vehicle.

ARB's modern Summit side rails and steps incorporate a sleek extruded aluminium step section and an integrated clamp system for bull bar attachment. For those not requiring side rails, a standalone step can be fitted.

→ Available for Ranger, Everest





Under Vehicle Protection

When travelling off road, the underbody of your vehicle is very susceptible to damage. ARB's under vehicle protection systems are designed to protect these vulnerable areas from rocks, logs and ruts, which can often be encountered in more challenging terrain.

→ Available for Ranger, Everest

Features

- Vehicle specific design
- Pressed and folded 3mm laser cut steel, providing more strength than folded steel alone and increasing the strength to weight ratio
- Protection panels are zinc plated and powder coated in a silver textured finish
- Recessed mounting bolts are protected and easy to remove for vehicle servicing
- Compatible with all ARB products
- Steel components are protected with either powder coat or zinc plating

Recovery Points

It is important to have strong, reliable recovery points when travelling off road. ARB has sought to set an industry benchmark for how recovery points are designed, tested and selected by 4WDers. Each vehicle specific recovery point undergoes considerable research and design, and is rated for use with a 4.75t rated bow shackle and an 8000kg snatch strap. Manufactured from steel plate, ARB's recovery points are rated for angled recovery and use vehicle specific mounting systems to ensure the fitment does not affect air bag deployment or the crash pulse of the vehicle.

→ Available for Ranger, Everest



Ascent Canopy

ARB's Ascent canopy features the latest in design, technology and functionality while providing extra storage and added security and protection for belongings during on and off road travel. Designed, engineered and assembled in Australia, the Ascent canopy has gone through a rigorous testing regime to ensure it can handle the harshest of conditions.

→ Available for Ranger

Features

- High flow canopy vent comes as standard on the Ascent range, pressurising the canopy to aid in inhibiting dust ingress
- Frameless, tinted and tempered safety glass used for exterior windows
- Stylish and functional interior design with maximum space and concealment of fasteners and wiring looms, where possible
- An electronic unlatching system and slam shut latches on the side and rear windows allow for one-handed operation
- Over-rail design which blends the canopy to the vehicle resulting in no visible seal
- LED interior light
- Rear spoiler which incorporates an LED brake light
- Anti-entrapment dial, which allows the rear window to be locked or unlocked from within the canopy
- Plug and play wiring harness allows for keyless entry and remote central locking
- Internal, low intrusion support frames utilised for roof rack and roof bar fitment







Removal Service

ARB

XLT

Ford

RANGER

4x4



Classic and Classic Plus Canopies

ARB's Classic canopy has stood the test of time, offering unrivalled quality, practicality and affordability, making it the perfect solution to increase the space and security of a utility vehicle. The Classic canopy can be tailored to suit different requirements and has an extensive range of accessories to complement it.

→ Available for Ranger

Features

- Weatherproof exterior, with a UV-rated finish
 - Central locking rear window offers added security for belongings stored in the canopy (Classic Plus only)
 - Sliding or lift up side windows available
 - Internal halogen light
 - LED brake light
 - Smooth, inert materials are used in the interior making it easy to clean
 - Side and rear windows are manufactured with factory tinted and tempered safety glass
 - The lift up side and rear windows operate via gas struts to assist with opening and closing
 - Available in a smooth or textured finish
 - Optional accessories for the Classic canopy include; security mesh for sliding windows, high flow canopy vent and lift up side windows
-



Tango Sport Lid

The Tango sport lid is an alternative to a permanently mounted canopy, providing secure storage and keeping your gear protected from the elements. With an option to mount roof accessories for additional storage, the top of the sport lid can hold a total of 75kg, with a maximum of 20kg if the lid is to be lifted with the cargo still mounted. Features include central locking via the vehicle key fob, soft touch electronic unlatching mechanism, LED interior light and emergency override of the locking mechanism.

→ Available for Ranger

Tango mount rails

The base for the whole Tango system, the Tango mount rails offer protection to the top of the tub walls, without interfering with OE tie down points or other accessories such as ute liners and Sportguards. For additional storage, a range of products can be added via the T-slots including Thule and Rhino roof bars and bike carriers.



Tango Loadmaster cargo organiser

Designed to slide into the T-slots on each side of the vehicle tub, the Tango Loadmaster cargo organiser is handy for sectioning areas and separating cargo in the tub. It incorporates two pockets along the length of the divider for storing smaller items.



Ute Liners

Compatible with all ARB canopies, ARB Sportguards and ute liners protect the ute tub from scratches, dents and corrosion, as well as common spills that might occur.

→ Available for Ranger

Sportguard

ARB's Sportguard utilises a simple snap fit, five-piece design, which can easily be installed in separate sections with no drilling required and retains factory tie down points. The anti-slip floor is a standout feature and the contoured design maximises tub space.

Ute liner

The one-piece design is vacuum formed to the shape of the tub, is UV stable and helps prevent load movement.







Roof Racks and Roof Bars

A roof rack is a valuable and versatile accessory for many touring and trade vehicles, and without one, some trips would just not be possible. It's the place for lightweight, bulky items that are difficult to fit in the cabin of the vehicle. And with additional accessories now available, such as waterproof bags, you don't have to worry about your gear being exposed to the elements while travelling.

ARB manufactures both steel and aluminium roof racks to suit a wide range of vehicle types, covering both recreation and commercial applications:

- Canopy roof racks and roof bars (Ranger only)
- Cab racks (Ranger only)
- Trade roof racks (Ranger only)

Additionally, ARB also stocks Thule and Rhino roof bars and accessories to suit most popular 4WDs, 2WDs and SUVs.

→ Available for Ranger, Everest



Old Man Emu



30

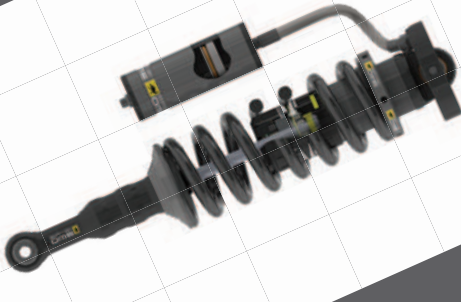

Old Man Emu has been the choice of suspension for 4WDers for many years due to the outstanding ride performance it delivers over all road surfaces. Integrated suspension packages are available to improve ride, handling and load carrying ability no matter what your requirements may be.



BP-51

The new BP-51 range of high performance, bypass shock absorbers is the result of an exhaustive development process aimed at delivering the ultimate in both comfort and control.

Designed, developed and tested entirely in-house by ARB's team of Old Man Emu Ride Control Engineers, BP-51 shock absorbers are vehicle specific and allow independent adjustment of both rebound and compression damping, to offer class leading ride customisation that can be tailored to individual vehicle or trip requirements.

→ Available for Ranger

Nitrocharger Sport

Nitrocharger Sport shock absorbers are an integral part of Old Man Emu's suspension systems, providing

a noticeable improvement every time the vehicle is driven. Built in Australia and trusted by 4WDers throughout the world, OME Nitrocharger Sport shock absorbers set the standard in fine tuning and ride comfort in any terrain, and simply outperform the competition.

→ Available for Ranger, Everest

Springs

Old Man Emu designs a range of coil and leaf springs, enabling the installer to match the most appropriate springs to the intended application. While ride height increases are attained, an emphasis is placed on ride control improvements.

Further fine tuning is achieved when the springs are matched to a corresponding set of Old Man Emu shock absorbers, delivering a fully integrated system, designed specifically to suit your vehicle.

→ Available for Ranger, Everest

GVM Upgrades

Whether you're carrying tools of the trade or packing up the 4x4 for an extended trip, your vehicle can become dangerous and illegal if it exceeds the allocated gross vehicle mass (GVM). To combat these issues, ARB offers Old Man Emu GVM upgrades in line with ADR requirements for a number of new, unregistered vehicles.

Speak to your local ARB store or authorised stockist for more information on GVM upgrades.

→ Available for Ranger

Hardware

Complete suspension integration is possible with Old Man Emu's range of hardware and accessories such as greaseable shackles, bushes and steering stabilisers.

→ Available for Ranger, Everest

Frontier Tank

The ARB Frontier diesel tank is a lighter alternative to steel tanks and its one-piece design utilises existing vehicle mounting points. Manufactured from a resilient, impact resistant, cross-linked polymer, each Frontier tank offers strength and rigidity and the UV stable plastic ensures these tanks will not rust or corrode.

- Ranger (2012 on) 140L diesel tank



Ranger Frontier tank shown



Other Accessories

Air Locker



Designed and manufactured in Australia, ARB Air Lockers provide increased traction at the flick of a switch, whether it's rock, clay, sand, snow or mud. With a state-of-the-art two-piece design and an uncompromising approach to manufacturing, Air Lockers are distributed in over 100 countries worldwide and are the most trusted locking differential on the market.

Fridge Freezers



Developed specifically for off road use, ARB's range of fridge freezers offer uncompromising performance, making them the perfect companion for off road travel, giving you the convenience of cold food and drinks, with rapid cool down and low power consumption. The range comes in four convenient sizes (35L, 47L, 60L, 78L), as well as the 60L Elements weatherproof fridge freezer.

Intensity LED Driving Lights



Engineered in Australia and manufactured in the USA, ARB's Intensity LED driving lights have been designed and manufactured to specifically meet the demand of 4WDers around the world.

Submersible to 3m and vibration tested to military specifications, Intensity LED driving lights are available in traditional round sizes (AR21 & AR32) for standard bull bar mounting, or as a light bar (AR40) for a unique integrated low profile mount, suitable for both bull bars and roof racks. Spot, flood and combination beam patterns are available (model dependent).

Recovery Equipment



When travelling off road, reliable and durable recovery equipment is paramount. ARB offers a large range of recovery gear that will help get your vehicle out of any sticky situation. The range includes snatch straps, recovery kits, tree trunk protectors, and cable dampers. ARB also supplies a range of electric winches and Hi-Lift jacks.

Reversing Camera Systems



ARB's range of reversing cameras and monitor systems offer exceptional reversing visibility and help to extend the driver's vision to the rear, side, roof or front of the vehicle. Designed with flexibility and superior performance in mind, there is a multitude of options to suit every individual, providing all round safety.

IPF Lights



To cater for the different lighting requirements of 4WDers all over the world, ARB distributes a range of IPF driving and fog lights, in addition to a large range of replacement headlamp bulbs.

Other Accessories

Dual Battery Kits



Perfect for powering additional accessories without running the risk of flattening the main battery and to give you peace of mind in the event of a main battery failure, ARB has a range of dual battery kits to choose from.

Air Compressors



ARB air compressors are available in both portable and vehicle mounted kits, and offer many advantages when exploring the great outdoors, such as inflating tyres and camping accessories, running air tools, activating Air Lockers, even reseating a tyre onto a wheel.

Outback Solutions Drawers



Modular in design for user customisation, Outback Solutions drawers can maximise the versatility of your vehicle's cargo space by being configured with fridge roller drawer, roller drawer with roller floor or roller floor. Manufactured from galvanised stainless steel with sealed roller bearings and commercial grade carpet for durability.

Safari Snorkels



A Safari snorkel helps protect your vehicle's engine from dust, snow and water ingestion, ensuring clean, dry air is always available, no matter what the circumstance. Manufactured in Australia from polyethylene, the Safari snorkel is UV stable and can handle the toughest of conditions.

Camping Accessories



ARB has a range of camping accessories to help you on your next weekend escape or off road adventure. Made from rugged and hardwearing materials and built for the great outdoors, the range was made to cope with the harshest of conditions. From swags and rooftop tents to chairs and general accessories, ARB has all your camping needs covered.

Stores

VICTORIA

Bairnsdale (03) 5152 1226
Ballarat (03) 5336 4605
Bendigo (03) 5445 7100
Brighton (03) 9557 1888
Dandenong (03) 9793 0002
Echuca (03) 5480 2600
Geelong (03) 5272 2611
Hoppers Crossing (03) 9749 5905
Keilor Park (03) 9331 7333
Pakenham (03) 5940 5500
Shepparton (03) 5822 1877
Somerton (03) 9460 9988
Traralgon (03) 5174 9190

SOUTH AUSTRALIA

Elizabeth (08) 8252 1599
Morphett Vale (08) 8186 6101
Regency Park (08) 8244 5001

ACT

Fyshwick (02) 6280 7475

NEW SOUTH WALES

Albury (02) 6021 2477
Artarmon (02) 9438 4484
Broken Hill (08) 8087 9250
Brookvale (02) 8507 3073
Dubbo (02) 6885 5777
Moorebank (02) 9821 3633
Newcastle (02) 4953 9555
Thornleigh (02) 9980 8855
Orange (02) 6369 0700
Penrith (02) 4731 1266
Port Macquarie (02) 6581 2500
St Peters (02) 9565 2455
Tamworth (02) 6762 0541
Wagga Wagga (02) 6925 8777
Wentworthville (02) 9631 7889

WESTERN AUSTRALIA

Canning Vale (08) 6254 2367
Geraldton (08) 9921 8077
Mandurah (08) 9583 3200
Osborne Park (08) 9244 3553
Wangara (08) 9409 5764
Welshpool (08) 9358 3688

NORTHERN TERRITORY

Alice Springs (08) 8953 0572
Darwin (08) 8947 2262

QUEENSLAND

Biggera Waters (07) 5537 8800
Bundaberg (07) 4153 2929
Burleigh Heads (07) 5535 9223
Caboolture (07) 5499 1955
Cairns (07) 4035 3350
Caloundra (07) 5491 4500
Capalaba (07) 3823 5900
Coopers Plains (07) 3277 2020
Jindalee (07) 3715 6400
Nundah (07) 3266 3255
Mackay (07) 4998 6888
Maroochydore (07) 5475 4011
North Lakes (07) 3491 9600
Rockhampton (07) 4922 7788
Springwood (07) 3493 3030
Toowoomba (07) 4632 1122
Townsville (07) 4728 0900

TASMANIA

Burnie (03) 6431 4494
Hobart (03) 6228 6822
Launceston (03) 6331 4190

HEAD OFFICE:

ARB 4X4 ACCESSORIES

42-44 Garden Street,
Kilsyth Victoria 3137 Australia
Tel: (03) 9761 6622
Fax: (03) 9761 6807
Email: sales@arb.com.au
Web: arb.com.au



9 332018 047298

Part No. 573222



ADVENTURE
AWAITS™

